



SoCalMLS Tempo™ MLS System

www.tempo.socalmls.com

Quick Start Guide

Issued 08/20/07

Copyright 2003 by MarketLinx Solutions®



 A Member of The First American Family of Companies (NYSE:FAF)

SoCalMLS
101 E Lincoln Avenue
Suite 120
Anaheim, CA 92805-3203
714-517-2600 / 800-995-2600
714-517-2604 Fax

www.socalmls.com

SoCalMLS Sidebar – The latest in MLS News

TEMPO@SoCalMLS.com

9/20/07

Table of Contents

Hardware and System Requirements	4
Log In	5
Tempo™ Multi-Panel Homepage	6
Tempo™ Help	7
Navigating Through Tempo's Navigation Bar	8
Customizing Tempo's Home Page	12
MLS Number Search	13
Viewing & Printing Listings	14
Map Listings	15
Email Listings	16
Email Opt-Out	18
Email Tools	20
Quick Search	22
Tips for Entering Search Criteria	23
Search	24
Statistics	24
Search Results	25
Viewing, Selecting, Printing Listings	27
Search By Map	28
Map Tools	29
Custom Search	31
Revising Custom Search	33
MLS Tour/Public Open House Search	34
Tempo™ Driving Directions	37
Roster	39
Adding Your Agent Photo to Tempo™	40
Adding Email Signature	41

Hardware and System Requirements

Minimum System Requirements

- Pentium 3 (or equivalent clone processor) or higher
- 500 MB of open Hard Disk space
- 128 MB of memory, more memory will provide better performance
- Windows 98 or higher
- Internet Explorer 6.x or higher. To check the version, go to Help on the Toolbar, then About Internet Explorer. You can download Microsoft Internet Explorer or the upgrade at www.Microsoft.com/ie in the Downloads section.
- SVGA monitor (800x600) and over 256 colors (1024x768 or above preferred)
- **DSL or Cable strongly recommended**
(If using dial up modem, no less than a 56K-baud modem)

Computer Settings

For optimum screen viewing and function, we recommend you set your display as described below. Check your computer manual or contact the manufacturer before making these changes. These changes will affect all windows programs.

- Go into Control Panel, select Display, then Settings
- Color- (High/True Color)
- Go to Advanced, select General and under Font Size choose Small Fonts or Normal 96dpi

Browser Settings

Printing Defaults - Setting your browser fonts & margins in Internet Explorer

- Choose File from the browser main menu and Click on Page Setup
- Delete any Headers and Footers that are displayed in these boxes
- Set left and right margins to 0.25", top and bottom to 0.25"
- Print a Report on your printer and check and make sure that everything "fits" on the page. If not, go back and reduce your Margin and/or Font settings until it does

Toolbars

- Choose View from the browser main menu
- Select Toolbars
- Make sure Standard is checked

Text Size

- Choose View from the browser main menu
- Select Text Size
- Select Medium

Home Page - Setting Tempo™ as your "Homepage"

- Launch the Internet Explorer browser. Go to your Tempo™ system website (URL) <http://www.Tempo.socalmls.com>
- Find Tools on the Internet Explorer menu and Click on it to drop down the pick list
- Choose Internet Options from the pick list
- Find the Home Page section under the General tab
- Click the button "Use Current"
- Finally Click OK at the bottom

Desktop - Creating an icon on the desktop for Tempo™

- Go to your Tempo™ site
- Select File
- Select Send
- Select Shortcut to Desktop

Favorites - Add your Tempo™ system to your Favorites

- Go to your Tempo™ login page
- From your browser menu, select Favorites
- Select Add to Favorites

Log In Using Your SafeMLS™ Token

To login, follow these four (4) easy steps:

1. The SoCalMLS Tempo™ MLS Internet Based system URL:

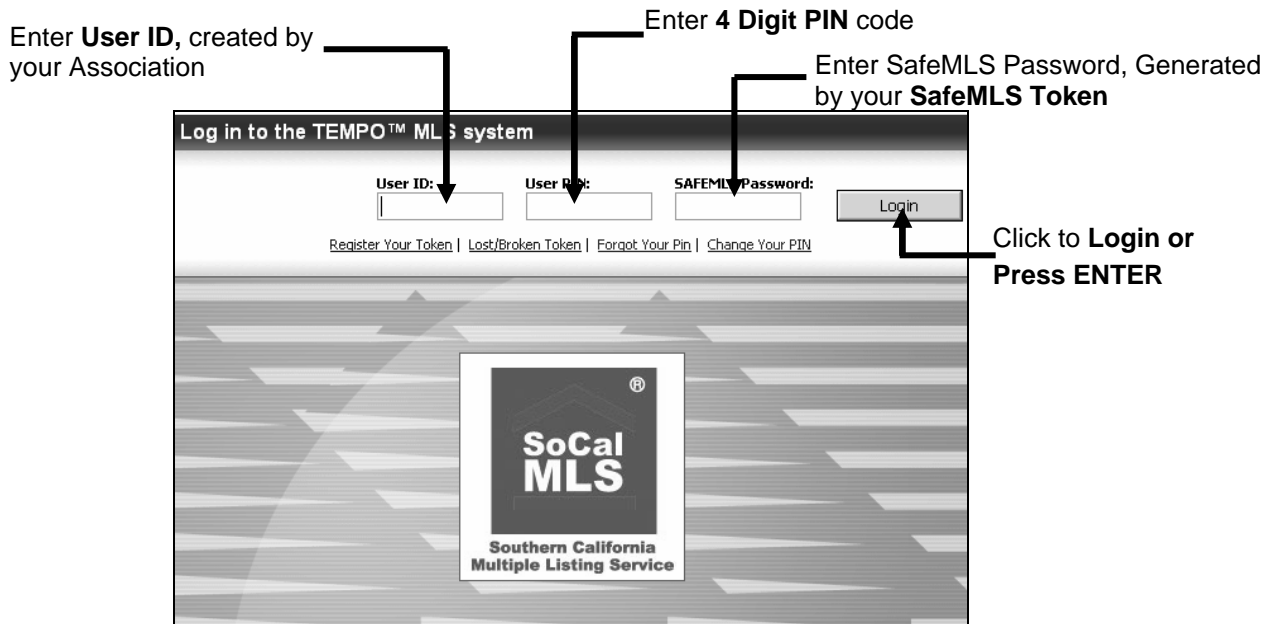

2. In the **SAFEMLS™ Login** section, type in your **User ID**
3. Type your **4 digit PIN code** in the User PIN field.
4. Press the **Gray** button on your **SAFEMLS™ token**. The token will generate a one time password. Type the one time password into the SAFEMLS™ Password field.



Note: Passwords are not case sensitive so it is not necessary to capitalize the letters. *In addition, all characters that look similar to letters or numbers are always numbers. For example 0's are always zeros and not the letter "O", 5's are always fives and not the letter "S".*

5. Click the **Log In button** (or press ENTER) to complete the login process.
- Note:** If you accidentally press the Gray button more than once prior to logging in and receive an invalid password message, simply press the button one more time and enter the next password generated. This will reset the synchronization of passwords assigned to your token.

This will take you to the Tempo™ Homepage.

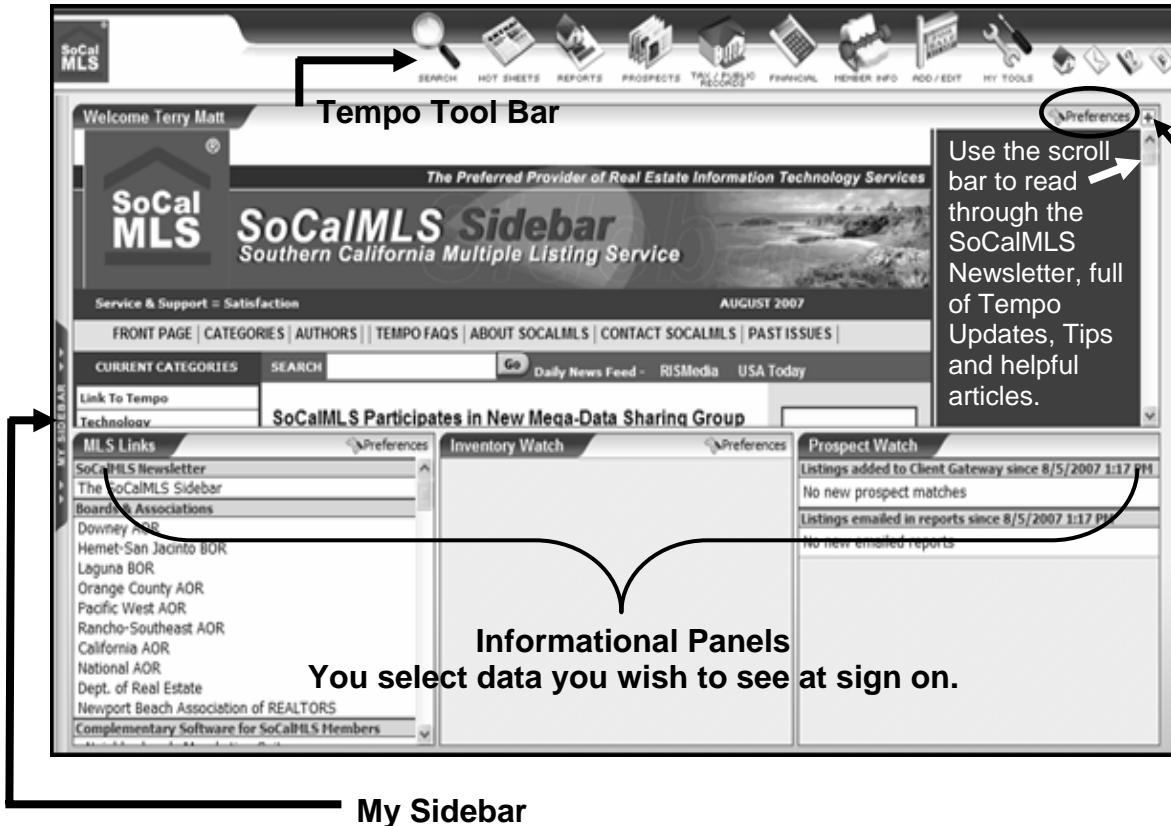

The Tempo™ Multi-Panel Homepage

The Tempo™ Homepage supports a Multi-Panel layout that allows you to easily access useful information at sign on. You design how you wish this screen to appear via the Preferences button in the upper-right corner (see page 12 for instruction).

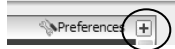

- Hover over any of the icons from the **Tempo Tool Bar** located at the top of the Homepage for a drop down menu of related functions, Click function you desire.
- The SoCalMLS Reporter is full of helpful information regarding Tempo Updates, Tips, SoCalMLS Free Training Class Schedule and Real Estate related articles. To View SoCalMLS Reporter in full screen Click the + at the top right corner of your screen.

Or Use the scroll bar to quick look for articles of interest.

- Click the Home icon  on the Navigation Bar to return to the Homepage.
- Click the envelope icon  to send an email to SoCalMLS Tech Support.
- Informational Panels provide instant access to information that you deem important. You may customize this screen and choose from a selection of options of panels you wish to appear on your homepage (see page 12 for instruction).
- Click *My Sidebar* to access this uniquely collapsible Tempo™ feature. *My Sidebar* provides links to Real Estate related web sites as well as shortcuts to view your Prospect updates and listing inventory.

Tempo™ Help

This document is a quick start guide only. The SoCalMLS Tempo™ system offers other forms of help for *all* functions.

Tempo™ On-Line Help

Simply Click the question mark (?) on the top right corner of the **Tempo™ Tool Bar** to open the online help module. This online help module opens in a new window so that you may utilize it without losing your place in the system.

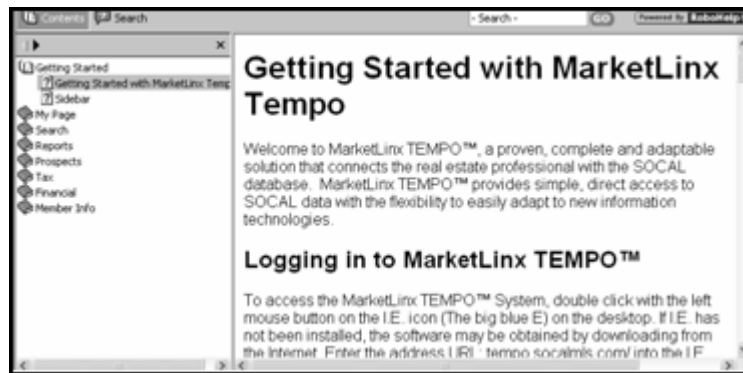

SoCalMLS Info Help

From Tempo™ Tool Bar, hover over **Member Info**, Click **SoCalMLS Info**.



This takes you to Tempo's™ **Forms, Flyers & News** where you will find:

- Online Video Tutorials
- Free Software Links
- SoCalMLS Newsletter Link
- Listing Forms
- Educational Articles
- Training Documents
- Tempo Updates and Tips
- Tempo Training Schedule
- Tempo Training Materials
- Access To Outside MLSs
- Economic and Market Watch Reports
- IDX Information
- SUPRA Information
- CASS Certificates – Realist Labels

Navigating Through Tempo's™ Tool Bar

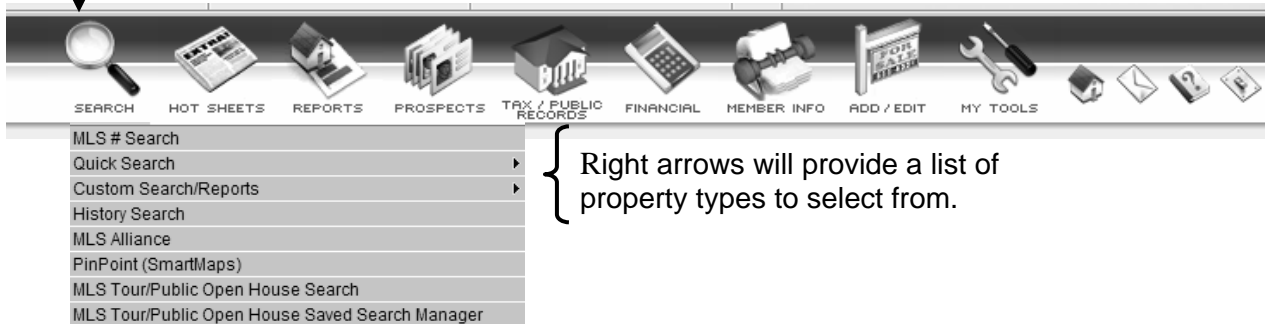

MLS # Search - The MLS Number Search allows the user to view specific MLS number(s) in various ways.

Quick Search - The Quick Search allows users to search for listings that match specific criteria, (i.e. location, price, number of bedrooms). The resulting information can be viewed in various types of reports including photos and Virtual Tours. Also available from Quick Search are the tools to map, email, send to listings to Client Gateway and view Tax Records.

Custom Search/Reports - Custom Search allows the user to create personalized searches. The user can design and save a Custom Search.

History - The History option allows the user to search for the archived history of a property either by an MLS#, property address, AP number or activity date.

MLS Alliance - Clicking on the MLS Alliance selection under Search on the navigation bar will link users to the California MLS Alliance site.

PinPoint (SmartMaps) - Smart Maps is a product provided to allow the user to search and map a property whether listed or not. PinPoint SmartMaps come fully equipped to provide users with aerial photos, parcel maps, property details and will link to tax records as well as listings on Tempo.

MLS Tour/Public Open House Search - This area allows you to search for MLS Tours and or Public Open Houses.

Navigating Through Tempo's™ Tool Bar

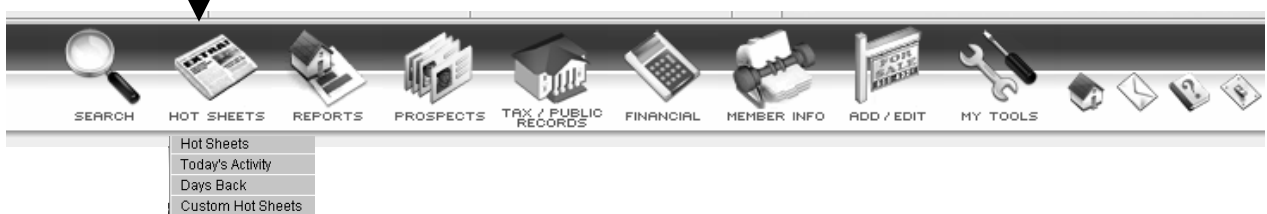

Hot Sheets - The Hot Sheet Report will identify new listings or listings that have changed in status or price **since the Hot Sheet was last time stamped**. Search criteria is based on City or cities, Property Type, Status and Price changes.

Today's Activity - Is the same as above only based on a time frame that begins at 12:01 am until the moment you run it.

Days Back - Is the same as Hot Sheet Report with the ability to select dates up to 45 days previous.

Custom Reports – Is the same as Hot Sheet Report with the ability to customize search criteria.

Navigating Through Tempo's™ Tool Bar

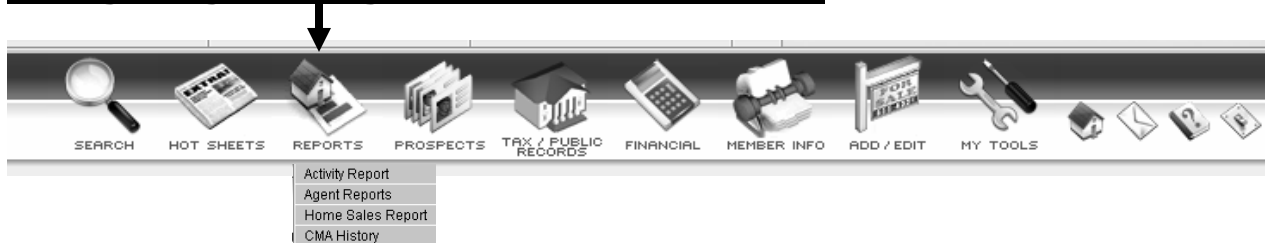

Activity Report - The Activity Report will identify listings by City or cities, Property Type or types for year to date or the month chosen.

Agent Reports - The **Agent Inventory** report is customized for each user so they can view all of their listings, organized by status.

Home Sales Report - Generate home sales statistics.

CMA History - Saved CMAs that were created within *Tempo*.

Navigating Through Tempo's™ Tool Bar

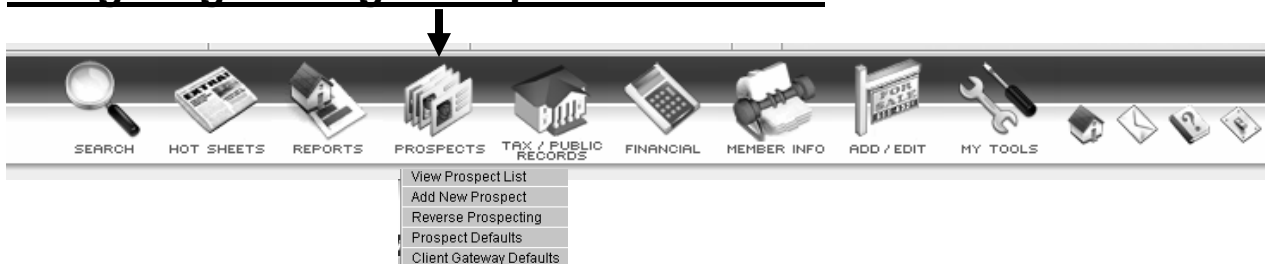

View Prospect List - Screen will give you a quick summary of all your prospect set ups, from this screen you may also run specified prospect searches

Add New Prospect - Click here to be taken to the Prospect Wizard where you will be walked through the steps required to Add your prospects to Tempo.

Reverse Prospecting - Quick and easy way to find agents with Prospects that match your active listing(s).

Prospect Defaults - Here is where users can set up defaults for their automated and/or manual emails that will be used with Prospects. Setting Prospect Defaults will save time and effort when adding a new Prospect.

Client Gateway Defaults - Users will desire to send links to a Prospect's personalized website (Client Gateway). The website will include chosen marketing or "branding information" about the agent. That information must be saved in Tempo.

Navigating Through Tempo's™ Tool Bar

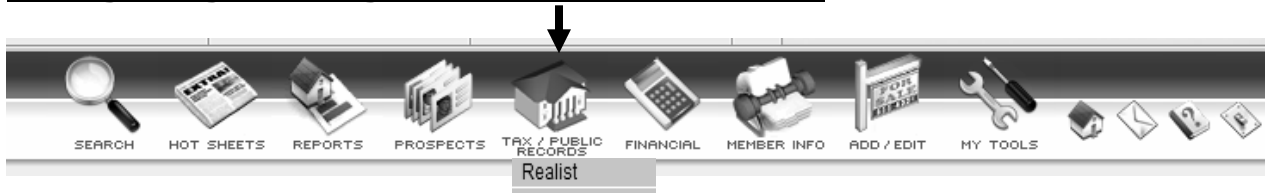

Tax - This will link users to Realist where they can search over 6,000,000 online tax records with sales transactions, from Imperial, Kern, L.A., Orange, Riverside, San Bernardino, Ventura and San Diego counties.

Navigating Through Tempo's™ Tool Bar

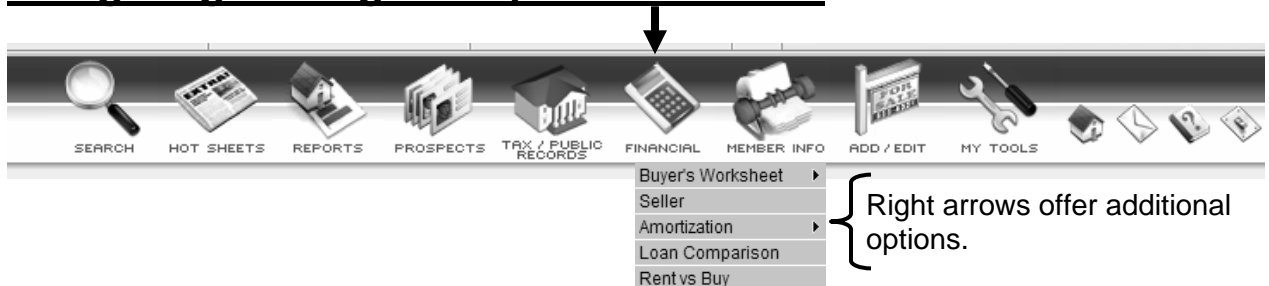

Buyer's Worksheet - calculates the estimated net funds required to close a property.

Seller - calculates estimated net proceeds by subtracting the seller's equity from the closing costs.

Amortization - summarizes monthly payments based on purchase price, down payment, interest rate, and loan period

Loan Comparison - The User can compare up to four (4) loans. Key in the loan information and calculations will be completed automatically for each loan.

Rent vs Buy - Rent vs. Buy allows the user to compare annual rental costs versus the cost of a home purchase.

Navigating Through Tempo's™ Tool Bar

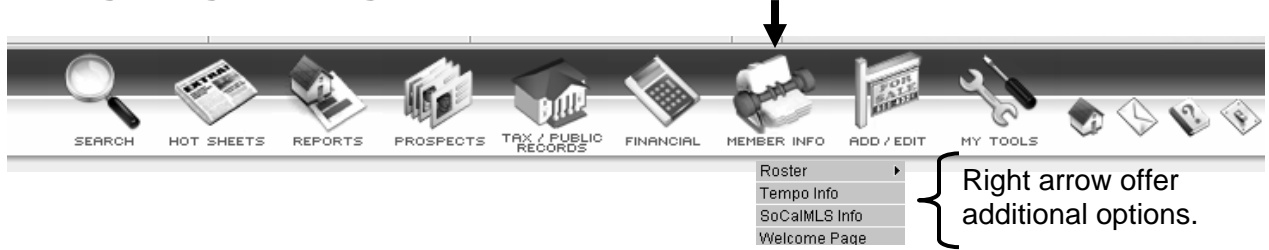

Roster - Here users can search for other SoCalMLS members, brokers and offices.

Tempo Info - This contains useful information geared for reciprocal users.

SoCalMLS Info - Here is where users can always find current Tempo information, listing forms, class schedules, training materials, training TUTORIALS along with other important Real Estate related information.

Welcome Message - This is timely information for SoCalMLS customers.

Navigating Through Tempo's™ Tool Bar

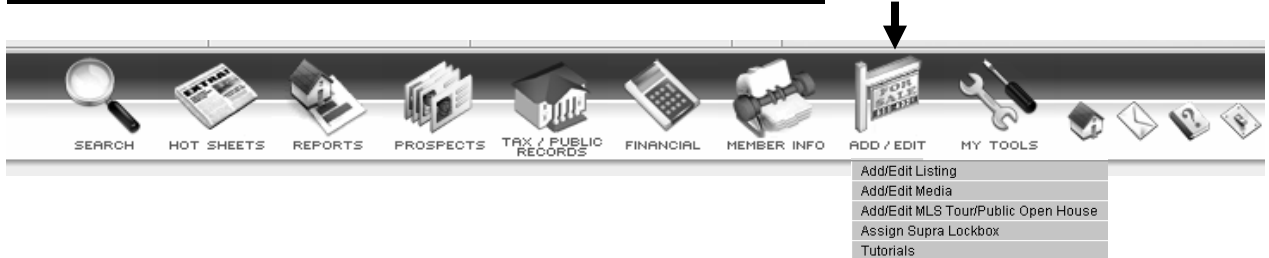

The **Add/Edit** section is where listings are entered, edited and viewed. If there is no link for **Add/Edit**, the user does not have permission (access) to this section.

Navigating Through Tempo's™ Tool Bar

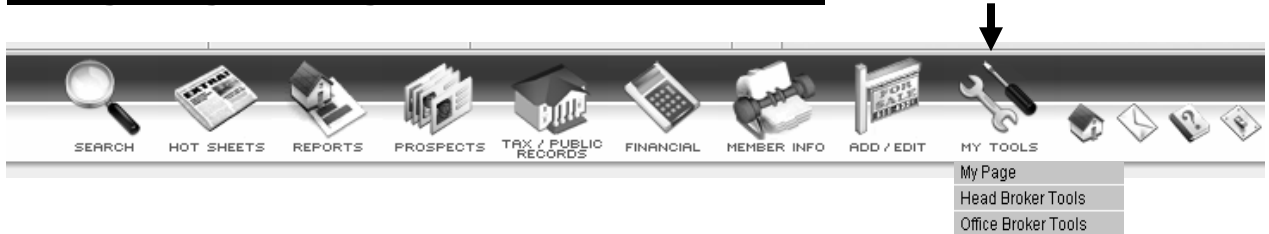

My Page - Here users can set their user Preferences, i.e. Add Photo, choose default sort, make changes to their Roster information and set up Sidebar homepage preferences.

Head Broker Tools – Head Brokers only have access to the following reports: Inventory, Office performance, Ranking Report, Agent Performance and Market Penetration.

Office Broker Tools – Office Brokers only have access to the following reports: Market Penetration, Agent Performance, Ranking Report, Agent Listing Performance Detail, Current Listings by Expiration.

Customizing Tempo's Home Page

You can design the content and layout of your home page by following the steps:

Step 1) Click the Preferences link, located in the upper right hand corner of home page

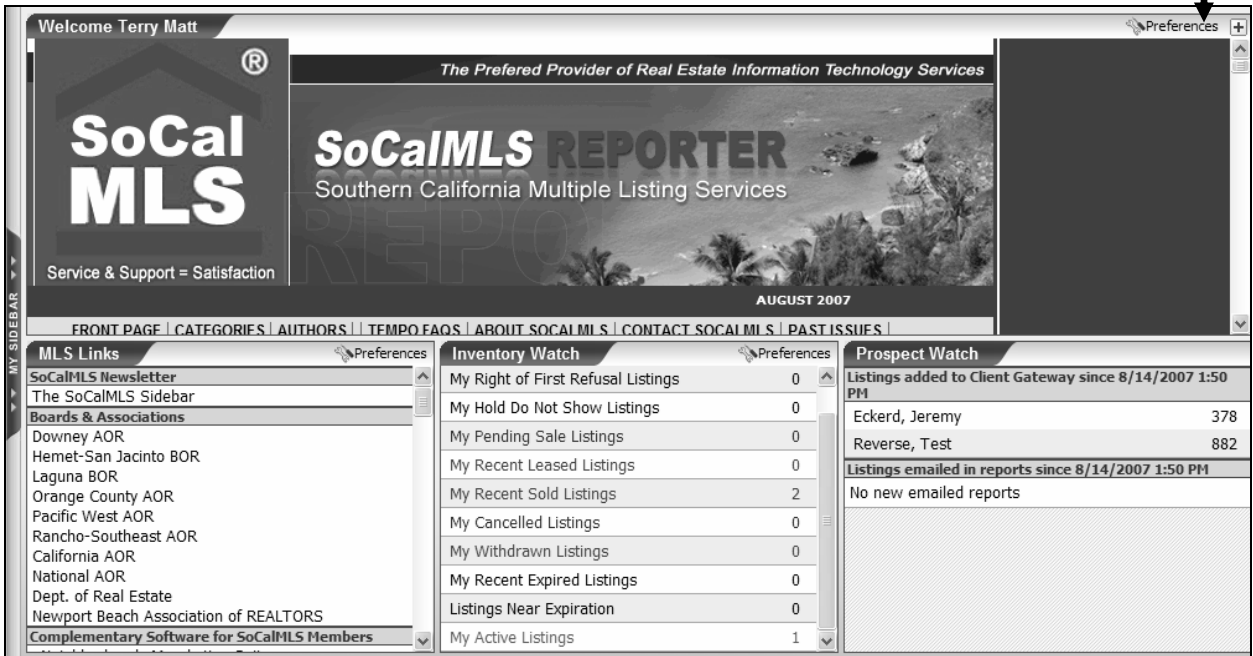

Step 2) Edit your Home Page by selecting the number of "portals" you wish to display.

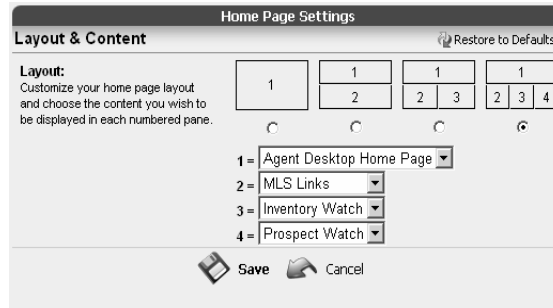

Select from 4 different display options by clicking the radio button beneath.

Step 3) Select the content that will appear in each "portal" by Clicking your preference.

NOTE: Agent Desktop Home Page (SoCalMLS Reporter) will always be in the number one window.

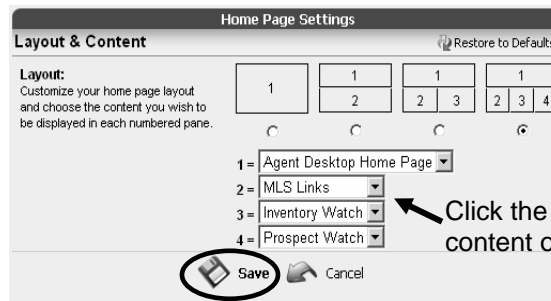

Click the ▼ for a list of content options.

Step 4) When finished, Click Save.

Step 5) Return to Tempo Home page by Clicking Exit Preferences, located at the bottom left corner of screen.

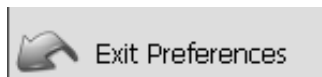

Searching Listings

The Tempo™ MLS provides three listing searches:

- 1) MLS Number Search
- 2) Quick Search
- 3) Custom Search

This document provides detailed instructions on each of these searches.

MLS Number Search

The MLS Number Search allows a user to quickly search listings when they already have the listing(s) MLS number(s).

To execute an MLS Number Search:

Step 1 From Tempo™ Navigation Bar, hover over *Search*, Click **MLS# Search**.



Step 2 The MLS # Search screen appears.

- Click in the text box and **enter valid MLS number(s)**.

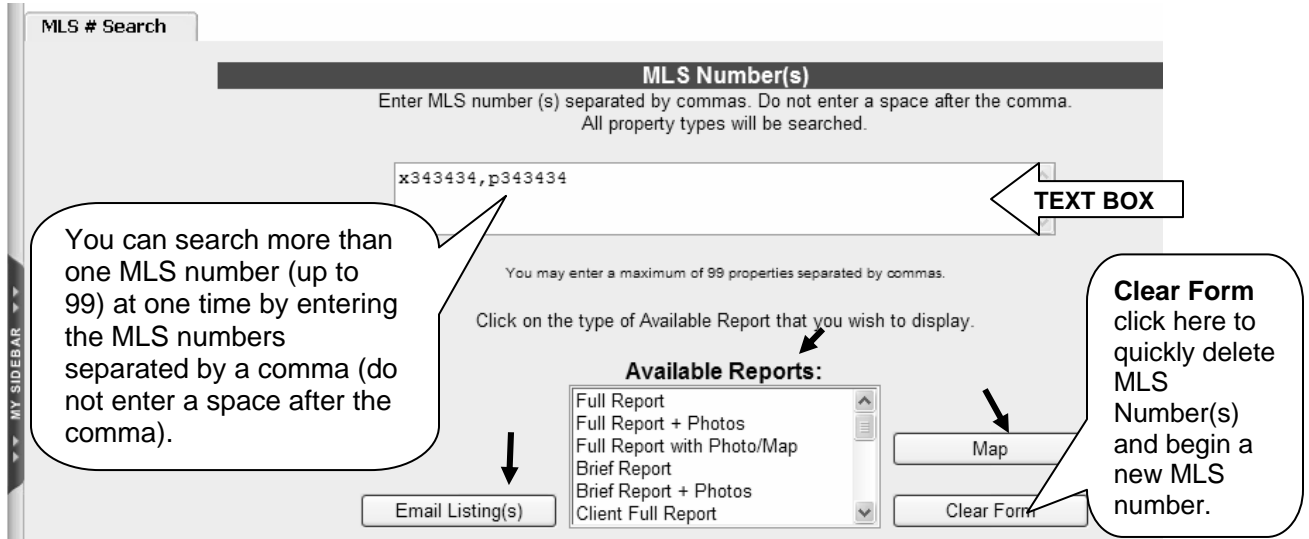

Step 3 Select the function you wish to apply to the listing(s) - your options are:



- **Available Reports** - This allows you to choose what report format you would like to view/print listing(s) in. Using the scroll bar to the right of the Available Reports box to view the complete list and Click your choice. (Go to page 8)
- **Map** - Click this button to place listing(s) on map, receive driving directions or print.
- **Email Listing(s)** - Click this button to email listing(s).

Viewing & Printing Listings



Use the scroll bar in the **Available Reports** box to view the complete list of reports then click your choice. Listings will be displayed in the chosen format.

Colored and underlined text in a report are links to additional information such as:

- Maps and directions from MarketLinx Mapping™, accessed through the address and Thomas Guide Number links. When finished with MarketLinx Mapping™, close the window. Do not close the Tempo™ window.
- APN will take you to the property tax record link through Realist.com. When finished with tax record, close the window. Do not close the Tempo™ window.
- Information about the listing agent from the roster, including contact information.
- The picture link provides an enlarged, high resolution picture or a series of pictures, which you can copy or save as a file by right-clicking to display a short cut menu, then left-clicking your choice. You can then use the copied or saved picture to create a flyer in the program of your choice.
- Click the  for an aerial view of property.
- Click the  button, to report a Listing Violation.

Residential Wed, Aug 8, 2007 04:36 PM

Terry Matt
SFR Detached RES Active **11 Winston Dr.** Coto De Caza (CDC) Price \$2,995,000*

Coto De Caza (CC) Zip 92679-5135 TGN0 92308
Orange County (OR) XSTS Vista del Verde/Devonwood Aerial Map 

S477376 Media: 4 Builder Tract (Weatherly (WEAT))
Bed 5 Model Fairbanks (B)
Baths 5.5 Style Other Stories Two Levels Floor of 2
View Canyon View, Mountain View, Trees/Woods View HOA Dues \$ 210 + \$ \$
ASqFt 5,800 Estimated YrBlt 2000 Assessor Land Fee
ALotSize 45,000 Estimated Dim Acres
Prkng Garage Attached

Garage 4 A Rem 2 Spc Cprt RV Acc Range 8: No

This spectacular estate has incredible panoramic views and is located on private road in the exclusive Weatherly neighborhood. Large chef's kitchen has double ovens and opens to spacious family room. Home has 5 Bedrooms (all are suites) and 5.5 baths. Upstairs deck with westward views of canyons and mountains provide an unbelievable sunset experience. The spacious backyard has custom pool w/waterfall, spa and BBQ and is perfect for entertaining. This estate offers complete privacy!

Rooms
Bedrooms: Main Floor Bedroom, Master Suite, Walk-In Closet, Living Rm, Living Rm, Entrance, Dining, Breakfast Counter/Bar, Breakfast Nook, Formal Dining Rm
Other Bonus Room, Den/Ofc, Family Room, Individual Laundry Room, Library, Loft, Separate Family Room

Amenities
Pool Private Pool, Gunite, Heated & spa Private Spa, Gas TV Firepl Family Security Automatic Fire Sprinkler System Throughout, Fire and Smoke
Filtered, Heated with Gas, In Heated, In Ground Cable Room, Living Detection System, Fire Sprinklers, Gated Community with Guard, Security
Ground TV Room System

Appliances Built-In Gas Range, Double Oven, Garbage Disposal, Other Barbecue Private, Turnkey
Gas Oven, Microwave, Trash Compactor

High or Mid-Rise Amenities

Showing Instructions

 Instr Call First, Go Direct, See Remarks
Comp 2.5% Dual/Var No List Type Exclusive Right To Sell/Full Service Occupant Owner Martha V Daniel
LockBox Front Door, Supra-SoCalMLS Management Company Phone List Office/Agent Info Consider Lease No Possession
Management Company Name Management Company Phone Gate Code Misc Sign on Property

List Office South Coast Capital & Realty (H02679) Office 949-459-6000 Fax 949-625-8383 Res 949-459-8332
List Agent Sonya Weaver-Johnson (sweavson) Pager 949-842-8876 Cell 949-842-8876 Primary 949-459-6000
Agt E-Mail Yes Agt WSite www.southcoastca.com

Priv Rmks Appointment must be made on Saturdays only. Otherwise, call first and then go direct. Open house every other Sunday from 1pm - 4pm. Call Sonya (949)842-8876 or Renee (949)690-2533 with questions or for Saturday appointments. THANKS FOR SHOWING!

Price Excl
Price Includes
Occupant Owner Occupant Name Martha V Daniel
Listing Activity

List Date 2/27/2007 Date Added 2/28/2007 Tran Date 7/23/2007 DOM 152 Exp Date 8/26/2007 LP/SqFt \$516.38
Org Price \$3,295,000 Prev Price \$3,195,000 Cur List Prc \$2,995,000 CDOM 162 Off Market Comp 2.5%

To Print listing(s) – right click anywhere on report, then click print.

All listings being viewed will print in the same format as is on your screen.



Map Listings - Map

- Click the Map button to plot listing(s) on map and or get driving directions.
- Each listing is numbered.
- Click the down arrow to the right of Street, (bottom left corner of your screen) then Click Thomas Brother's to add a Thomas Brother grid overlay to the map.

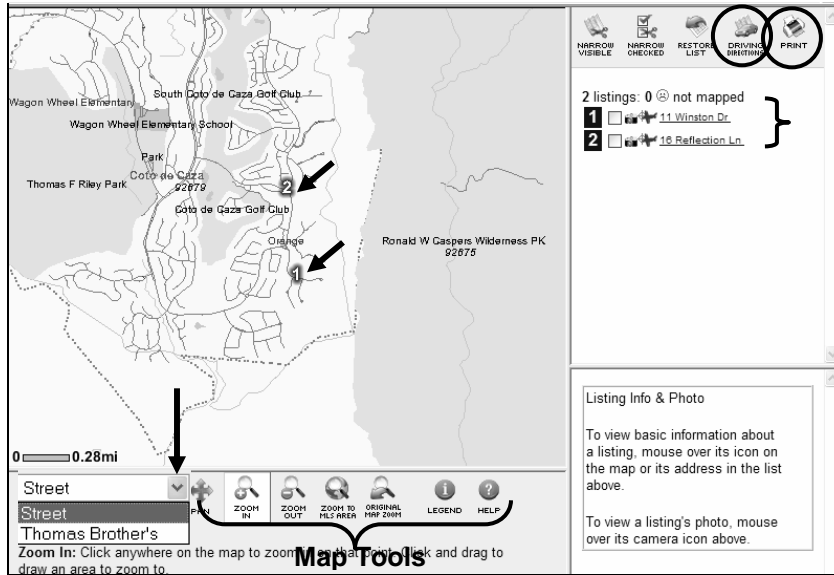

- Clicking on address link will open full listing report.
- Clicking on airplane will link to aerial view of property
- Hover over camera to view primary property photo

- Map Tools provide the ability to: Pan, Zoom In and Zoom Out as well as Zoom to MLS Area, Original Map Zoom. A legend is provided and map help.
- Click Driving Directions (icon at the top right of map screen) to obtain driving directions to properties.
- Click Print (icon at top right corner of map screen) to print map.

Map with Thomas Brother's grid overlay:



E-Mailing Listings - Email Listing(s)

Click the E-Mail Listing(s) button on the MLS Number Search screen to open the e-mail page.

Click the **Add** button () if you have already added client's email address to your Prospect list. This will provide a list of all prospect email addresses for you to select from.

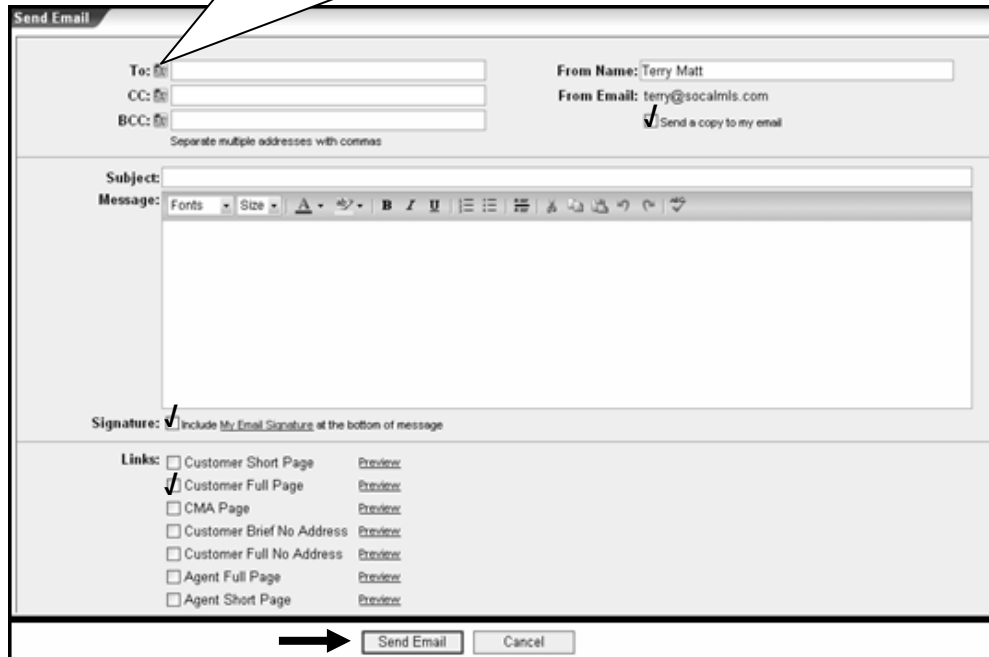

Send Email

To:

CC:

BCC:

Separate multiple addresses with commas

From Name: Terry Matt

From Email: terry@socalmls.com

Send a copy to my email

Subject:

Message:

Signature: Include My Email Signature at the bottom of message

Links:

- Customer Short Page [Preview](#)
- Customer Full Page [Preview](#)
- CMA Page [Preview](#)
- Customer Brief No Address [Preview](#)
- Customer Full No Address [Preview](#)
- Agent Full Page [Preview](#)
- Agent Short Page [Preview](#)

- Enter the e-mail address of the client in the *To:* box. You may enter multiple e-mail addresses by separating them with commas.
- The **From Email:** box is automatically filled with the user's e-mail address.
- To receive a copy of the e-mail, check **Send a copy to my email.**
- Fill in the **Subject:** then type your **Message.**
- If you have already set up a Default Signature (see page 30), Click the Signature Box to include.
- **Links:** Select a Report format.
- **Preview** the Report(s), if necessary.
- Click the **Send** button to email the listing(s).

- A confirmation will appear indicating the message has been sent and will display the listing information sent to the client. If you'd like to print a copy, Click the **Print** button on the browser toolbar to print a copy of the confirmation message.

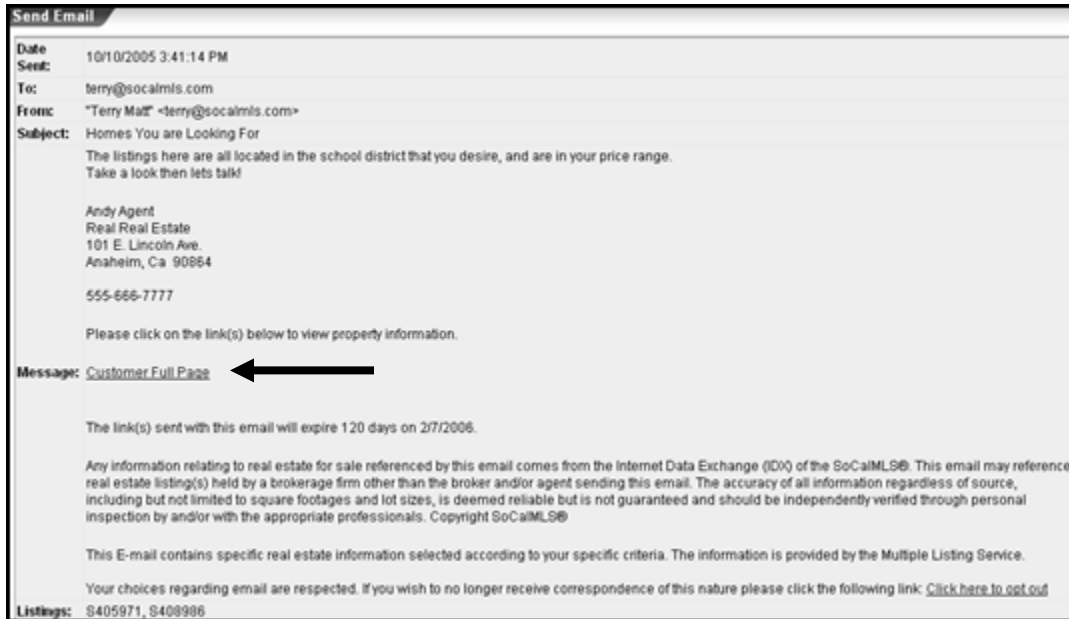

- The e-mail recipient clicks a link to view the listing. The number of links the client receives depend on how many report formats the sender selected.



When the recipient clicks any of the report links, they will be taken to the live Tempo™ site and shown only the listing(s) the Tempo™ user has selected for them to view. The recipient may reopen the e-mail at a later date and click the report link to receive up to date information on the listing(s), including any changes.



Some e-mail applications do not display URL's as links in messages. In those cases, recipients of the e-mail listings should copy the URL from the e-mail message and paste them into their browser's Address bar.

Tempo™ MLS System Email Opt-Out

In compliance with the recent CAN-SPAM Act, as well as pressures from consumers and state and federal governments, SoCalMLS is proactively taking steps to protect both you, our customer, and ourselves from the unintended consequences resulting from the sending of email from the Tempo system.

This will also assist you in getting your message to your client by preventing emails from Tempo from being classified as SPAM.

When email is sent from the Tempo system, a link to an Opt-Out form will be appended to the footer of each email, giving recipients the option to Opt-Out of receiving future emails from the sender, along with the ability to comment on why they no longer wish to receive email.

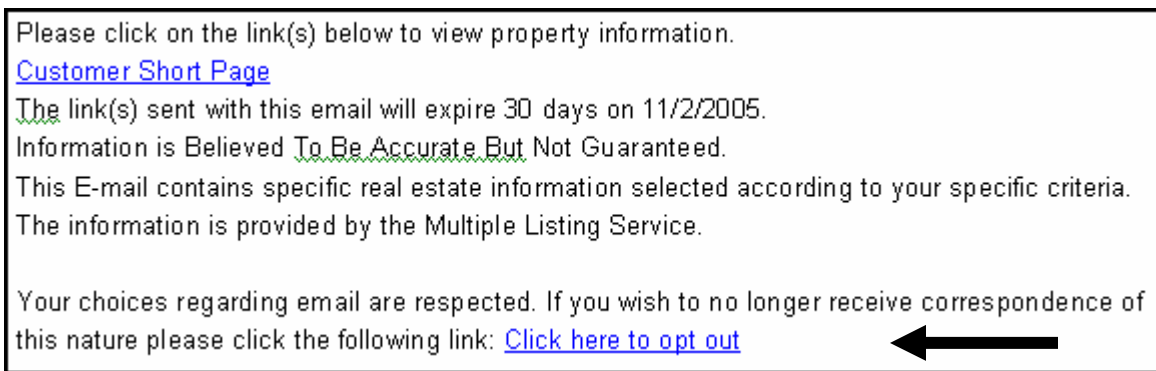

- Should they click, [Click here to opt out](#) the following screen will appear:

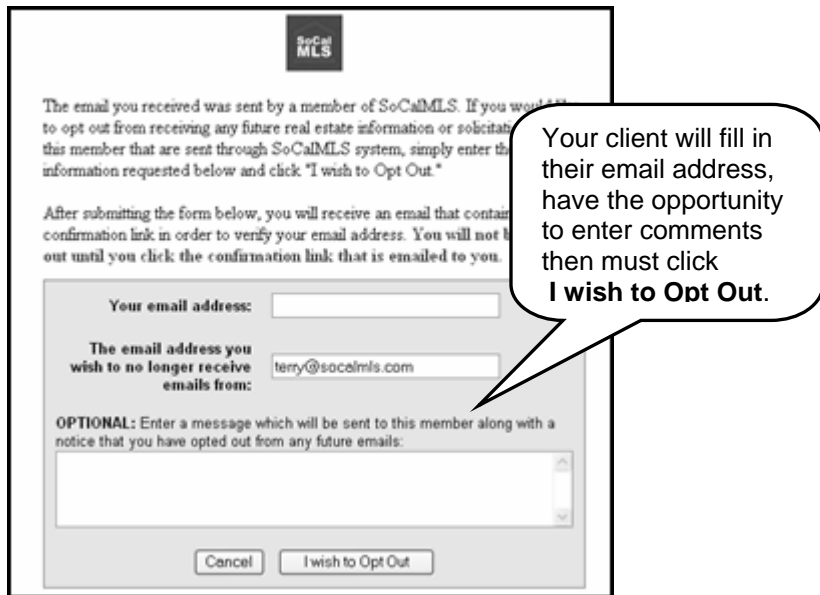

- Your client will then receive an email from SoCalMLS to confirm their wish to opt-out.

A request was made to opt out your email address from any future emails sent by John Agent (johnagent@yahoo.com). Click on the link below to confirm that you wish to no longer receive email from this sender.

If part of the link goes to a second line, copy and paste the entire link into your browser.
<http://socalistingsstage.marketlinx.com/optout/ConfirmOptOut.asp?id={8258B820-C7CE-4852-B054-D694D716D28C}>

- When a consumer opts out, the agent is sent an email notification of the opt-out.

The owner of the email address - JoeClient@yahoo.com - requested that they no longer receive Tempo email from you. Their request has been recorded by the Tempo system and you will be unable to send further Tempo emails to this address.

The following comments were provided by the owner of this email address when they requested to opt out of future emails:
We are no longer looking to purchase a home.

It is important for all members to respect people's right to opt-out of commercial emails. Ignoring this request and continuing to send email to this address is a violation of federal law.

- That agent can no longer send emails to their address from Tempo™, either manually or via auto-notification.
- Other agents can still send email to an address that is opted-out.
- If opted-out address is tied to a prospect, any other addresses associated to that prospect will continue to receive emails.
- Should the consumer change their mind they can easily opt back in
Here's how it works:
 - Consumer notifies agent that they wish to receive emails
 - Agent sends email to optin@socalmls.com , email *MUST* include agent's Public ID *AND* client's email address.
 - An email will be sent to client, client will receive opt in email from SoCalMLS

Due to a previous request you made, your email address is currently blocked from receiving email sent by John Agent (johnagent@yahoo.com) a member of [SoCalMLS](#).

If you wish to unblock your address and allow John Agent to send you email again, click on the link below. If part of the link goes to a second line, copy and paste the entire link into your browser. <http://socalistingsstage.marketlinx.com/OptOut/ConfirmOptIn.asp?id={8258B820-C7CE-4852-B054-D694D716D28C}>

- When client 'unblocks' their email address per the directions of email they receive, agent will receive email below:

The owner of the email address JoeClient@yahoo.com has confirmed that they wish to again receive email that you send them from the Tempo system.

Tempo™ Email Tools

Tempo™ provides the tools that help you add creativity and professionalism to your emails!

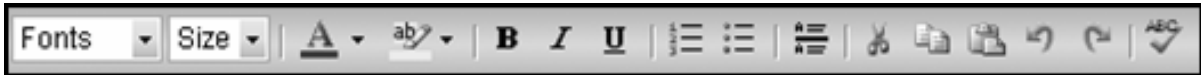
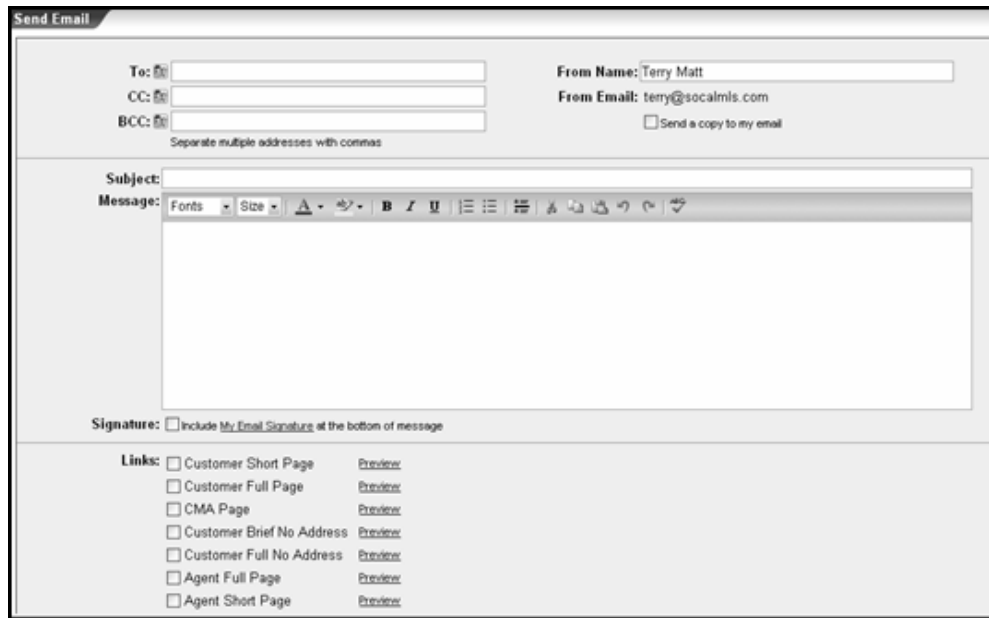

Click the Down arrow and choose from the fonts available.



Click the Down arrow and choose from the font sizes available.

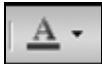

Click the Down arrow and choose from the font colors available.



Highlight specific text then click the Down arrow and choose from the colors available.



Use this to **Bold** specific text.



Use this to *Italicize* specific text.



Use this to underline specific text.



Click to number items on a list.



Click to bullet items on a list.



Click to add blank lines to your email message.



CUT - Highlight text, click to cut and remove or move text.



COPY - Highlight text, click to copy.



PASTE - Place cursor where you wish to paste text.



UNDO - Click here to erase your last step.



REDO - Click here to bring back your last step.



Click to Spell Check your message.

Quick Search

The Quick Search allows searches for listings that match specific criteria (i.e. city, price, number of bedrooms, etc.). The resulting information can be viewed in any of the Available Report formats.

Step 1 From Tempo™ Tool Bar, hover over **Search**, Click **Quick Search** and the Quick Search screen will appear.



Step 3 The Quick Search screen contains the property criteria to be searched in the available property types (i.e. Residential, Commercial, Land and Business, etc.)

Click tab that reflects property type of your choice

Residential Res Lease Res Income Mobile/Modular/Manufactured Land Commercial Com Lease Business All

Search

Statistics
Download
Plot on Map
Search by Map
Save Custom Search
Clear

Select
Type in codes for the selections separated by commas or click on "Select" below.
County
City
Area

Status
Clear Check All
Active Off-Mkt
-- ALL --
Active
Backup Offers
Cancelled
Closed Sale
Expired
First Right of Refusal
Hold Do Not Show
Leased
Pending Sale
Withdrawn

Property Information
Price Min Max
Beds
Baths
Living SqFt
Year Built
Garage
Lot Size
Compensation N/A
Images
Floor Entry
Virtual Tour N/A Yes No
Fireplace N/A Yes No
Land Title N/A Fee Lease
Mello Roos
Range Price N/A Yes No

Attached/Detached
N/A
Attach/Detach Attached
Detached

Address
Street Number Min Max
Street Name
Unit Number
Direction -- ALL --
East
North
South
Or And Not
Zip Code
TGNO

Listing Information
List Date Min Max
High School Dist. Select Clear
APN #
List Agent ID
List Office ID
MLS Number

Tract Information
Bldr Tract Code Select Clear
Bldr Tract Name
Model Code
Model Name
Tract No.

Off-Market Information
Sale Price Min Max
Last Action Date
Pending Date
COE/End Date
Days On Market
Sell Agent ID
Sell Office ID

Floating Toolbar

Floating Toolbar:

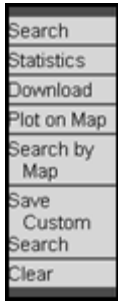

- Search** - Click here for listings that match your search criteria
- Statistics** - Click here for a quick statistical summary of listings that match search criteria
- Download** - Click here to Download matching listings
- Plot on Map** - Click here to plot matching listings on a map
- Search by Map** - Click here to focus your search on property location
- Save Custom Search** - Click her to save search criteria to be accessed again
- Clear** - Click here to delete all search criteria entered

Tips for Entering Search Criteria

- City is the only required data. If you wish to include all cities, type the percent sign (%) in City field – this is the wild card and will include all cities.
- To select more than one item in a list, hold down the CTRL key on the keyboard while clicking on each item to be included in the search.



- Do not put spaces or commas in numbers. Remember to use the number key Zero (0) and not the letter “O”.
- When entering a date, use the slash (/) that is located beneath the question mark (?) on the keyboard. To use January 1, 2004 enter 01/01/04.
- Tempo™ can also perform a *Negative Search*. This searches for everything EXCEPT the specified criteria that has a minus sign in front of it. Example below will search every city with the exception of La Mirada (LAM).



- The Tempo™ system uses the % for a wild card and automatically places one behind any typed text. The user can insert one manually before any typed text. Example below will find listings on page 765 all Columns (%) in row 4 of Thomas Guide.



- The boxes in the left column on the Min/Max section are for minimum values and the boxes in the right column are for maximum. Numbers can be entered in the Min or Max column, both columns or left blank.
- And / Or/ Not radio buttons:



Or – should you click more than one option, Or tells Tempo™ that you are looking for at least one of the items your selected.

And – should you click more than one option, And tells Tempo™ that you listing must have all of the items you selected.

Not – Not tells Tempo™ that listings with items selected, should be eliminated from your search.

- Sorting listing results

Quick Search Sorting Preferences		
Sort Code 1	Sort Code 2	Sort Code 3
Default Setting MLS # A/D Area Bedrooms	Default Setting MLS # A/D Area Bedrooms	Default Setting MLS # A/D Area Bedrooms

You may control the order that your listings are presented to you by selecting the main sort (Sort Code1), Sub sort (Sort Code 2) and the Sub-sub sort (Sort Code 3).

Search

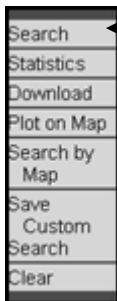

The **Search** button (found on the Floating Toolbar) when clicked, will immediately go to the one line item results page and allows the user to see up to 250 matching listings.



Statistics

– To receive a quick snapshot view of listings that match your search criteria before actually viewing the one line item results page, Click **Statistics**.

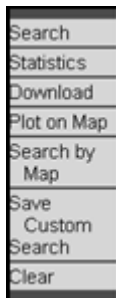

Statistics provides valuable statistical information, such as total number of listings found for each status and the minimum, average and maximum of certain fields.

Statistics Results									
Active - 4 Properties Found									
	Bedrooms	Baths	Square Feet	List Price	LP/SqFt	Sale Price	SP/SqFt	SP/LP	DOM
Min	3	3.5	0	\$4,450,000	\$0	\$0	\$0	%	39
Avg	4	5.25	3675	\$6,547,688	\$888	\$0	\$0	%	100
Max	5	6.5	5700	\$9,250,876	\$1,399	\$0	\$0	%	213
Closed Sale - 12 Properties Found									
	Bedrooms	Baths	Square Feet	List Price	LP/SqFt	Sale Price	SP/SqFt	SP/LP	DOM
Min	4	4.5	7200	\$4,495,000	\$449	\$4,000,000	\$410	76%	0
Avg	6	7.50	9949	\$6,676,158	\$673	\$6,267,916	\$625	93%	105
Max	8	9.5	15000	\$15,000,000	\$1,395	\$15,000,000	\$1,395	100%	266
Your Search Criteria Returned 16 Properties									
Enter Number of Properties to View: 16 (250 maximum)									
<input type="button" value="View Requested Listings"/> <input type="button" value="Revise and search again"/>									
Search Criteria: (ListStatus IN ('act','clsd')) AND ((SearchPriceLow>=4000000) OR (SearchPriceHigh>=4000000)) AND Tbl.City IN ('cod')									

Click on the *View Requested Listings* button to bring up line item results page.

Click on the *Revise and Search Again* button to either expand or refine the search.

Search Results Page

The search results are listed in a one-line printout format. Items that are underlined are links:

Residential
Res Lease
Res Income
Mobile/Modular/Manufactured
Land
Commercial
Com Lease
Business
All

Total number of properties found: 8

Click on Any MLSNO to Preview and Select Listings:

Number of properties displayed: 8 out of 250 maximum.

Search Functions

▼

Thu, Aug 9, 2007 05:40 PM

Residential																								
RES	MLS #	Status	P	V	H	T	Q	Type	A/D	Address	City	Area	Zip	TGNO	Trct/M	Bd	Bth	Sty	Gar	SqFt	Yr Blt	Price	DOM	
1	<input type="checkbox"/> S477376	A	<u>4</u>		<u>H</u>	<u>T</u>	<u>Q</u>	SFR	D	11 Winston Dr	CDC	CC	92679	923C6	WEAT/B	5	5.5	2	4 A	5,800	2000	\$3,195,000	163	*
2	<input type="checkbox"/> S488772	A	<u>8</u>		<u>H</u>	<u>T</u>	<u>Q</u>	SFR	D	7 Windcroft Dr	CDC	CC	92679	923C5	WEAT/1	5	5.5	2	5 A	5,629	1999	\$3,195,000	84	
3	<input type="checkbox"/> S491492	A	<u>18</u>		<u>H</u>	<u>T</u>	<u>Q</u>	SFR	D	23781 Via Roble	CDC	CC	92679	893B6	TF//	4	4.5	2	3 A	6,000	1989	\$3,295,000	70	
4	<input type="checkbox"/> S481033	A	<u>20</u>		<u>H</u>	<u>T</u>	<u>Q</u>	SFR	D	7 Shire	CDC	CC	92679	923B2	WDS/z	5	6.5	2	3	5,400	1995	\$3,750,000	118	*
5	<input type="checkbox"/> S446517	A	<u>20</u>	<u>V</u>	<u>H</u>	<u>T</u>	<u>Q</u>	SFR	D	12 Via Terracaleta	CDC	CC	92679	893B5	TA/Z	5	5.5	S	2 D	7,615	1990	\$3,890,000	413	
6	<input type="checkbox"/> S495259	A	<u>20</u>		<u>H</u>	<u>T</u>	<u>Q</u>	SFR	D	9 Raeburn Ln	CDC	CC	92679	923C6	ATTN/3	5	4.5	2	5 A	5,540	1999	\$3,895,000	41	
7	<input type="checkbox"/> S486557	A	<u>14</u>	<u>V</u>	<u>H</u>	<u>T</u>	<u>Q</u>	SFR	D	31592 Vinedo Rd	CDC	CC	92679	893C3	LRE/Z	3	3.5	1	4 A	3,100	2004	\$3,995,000	86	*
8	<input type="checkbox"/> S490742	A	<u>18</u>	<u>V</u>	<u>H</u>	<u>T</u>	<u>Q</u>	SFR	D	9 Havenhurst	CDC	CC	92679	923D4	WEAT/C	5	5.5	2	4 A	5,850	2000	\$4,995,000	70	

Results List Functions

Report Functions

Full Report

Full Report + Photos

Full Report with Photo/Map

Brief Report

Brief Report + Photos

Client Full Report

Links:

- Click on the MLS number to view the Agent Full Report for that listing.
- Header **P** is for **Photos**, Click the **corresponding number** to view listing photo(s)
- Header **V** is for **Virtual Tour**, Click **V** to view listing virtual tour
- Header **H** is for **Listing History**, Click **H** to view over 8 years of listing history
- Header **T** is for **Tax**, Click **T** to view listing tax record and other functions Realist provides, i.e. Comparable Properties, Document Image, Realist Map, Flood Map, Assessor Map, Neighborhood Profile
- Header **Q** is for **Quick Point Aerial map**, Click **Q** for an Aerial view of listing
- Click **Address** to **Map** listing and generate **Driving Directions**

Prices can be one of three colors:

- Black - this is the original price of listing, listing has not had a price change
- Green - there has been a decrease in price of listing
- Red - there has been an increase in price of listing

Search Results Page Continued

Residential Res Lease Res Income Mobile/Modular/Manufactured Land Commercial Com Lease Business All

Total number of properties found: 8
Click on Any MLSNO to Preview and Select Listings:
 Number of properties displayed: 8 out of 250 maximum.

Thu, Aug 9, 2007 05:40 PM

RES	MLS #	Status	P	V	H	T	Q	Type	A/D	Address	City	Area	Zip	TGNO	Trct/M	Bd	Bth	Sty	Gar	SqFt	Yr Blt	Price	DOM
1	<input type="checkbox"/> S477376	A	4		H	I	Q	SFR	D	11 Winston Dr.	CDC	CC	92679	923C6	WEAT/B	5	5.5	2	4 A	5,800	2000	\$3,195,000	163 *
2	<input type="checkbox"/> S488772	A	8		H	I	Q	SFR	D	7 Windcroft Dr.	CDC	CC	92679	923C5	WEAT/1	5	5.5	2	5 A	5,629	1999	\$3,195,000	84
3	<input type="checkbox"/> S491492	A	18		H	I	Q	SFR	D	23781 Via Roble	CDC	CC	92679	893B6	TF//	4	4.5	2	3 A	6,000	1989	\$3,295,000	70
4	<input type="checkbox"/> S481033	A	20		H	I	Q	SFR	D	7 Shire	CDC	CC	92679	923B2	WDS/z	5	6.5	2	3	5,400	1995	\$3,750,000	118 *
	<input type="checkbox"/>	A	20	V	H	I	Q	SFR	D	12 Via Terracaleta	CDC	CC	92679	893B5	TA/Z	5	5.5	S	2 D	7,615	1990	\$3,890,000	413
	<input type="checkbox"/>	A	20		H	I	Q	SFR	D	9 Raeburn Ln.	CDC	CC	92679	923C6	ATTN/3	5	4.5	2	5 A	5,540	1999	\$3,895,000	41
	<input type="checkbox"/>	A	14	V	H	I	Q	SFR	D	31592 Vinedo Rd.	CDC	CC	92679	893C3	LRE/Z	3	3.5	1	4 A	3,100	2004	\$3,995,000	86 *
	<input type="checkbox"/>	A	18	V	H	I	Q	SFR	D	9 Havenhurst	CDC	CC	92679	923D4	WEAT/C	5	5.5	2	4 A	5,850	2000	\$4,995,000	70

Search Functions:

Results List Functions:

Report Functions:
 Full Report
 Full Report + Photos
 Full Report with Photo/Map
 Brief Report
 Brief Report + Photos
 Client Full Report

Click white box to select individual listings.

Scroll down to view the variety of reports available. Click on report you wish use for viewing, printing and/or emailing your listing(s).

Results List Functions:

Listing(s) must first be selected to use Results List Functions.

Click:

- Check All Listings
- Email Listing(s) –
- Download
- Statistics
- CMA Wizard
- Narrow Listing(s)
- Map
- Revise Search
- Send to Prospect

To:

- select ALL listings
- email selected listing(s)
- download selected listing(s)
- obtain statistical data on selected listings
- create professional CMA report using selected listings
- remove all listings that have NOT been selected
- place selected listing(s) on map
- go back to quick search screen
- place selected listing(s) on prospect's Client Gateway

Report Functions:

Click:

- Custom Reports
- View Search Criteria

To:

- create new custom report
- view criteria you entered for search

Viewing, Selecting, Printing Listings

From the Search results screen Click MLS number of any listing to view listings in the Full Report.

Full Report

The screenshot shows a detailed real estate listing page. At the top, there are navigation buttons: 'To List', '<< Prev', '1 of 4', 'Next >>', a 'Select' checkbox, and a 'Full Report' dropdown menu. The listing is for a residential property in Costa Mesa, CA, with a price of \$4,450,000. The page includes a photo of the house, a map, and various details such as bedrooms, bathrooms, square footage, and price. The page also includes contact information for the listing agent and a 'Full Report' button.

The screenshot shows a toolbar at the top of a page. It contains buttons for 'To List', '<< Prev', '1 of 5', 'Next >>', a 'Select' checkbox, a 'Full Report' dropdown menu, and a 'Print' button.

From the Agent Full Report use the toolbar at the top of the page to:

- The *Next* and *Prev* buttons allow quick navigation through the list of search results without continually going back to the property listings page.
- Click the *Select* checkbox to mark the listing as being of interest. This has the same effect as checking the select box next to the MLS number on the line item results page.
- The *To List* button displays the search results again.
- To change the *View Format*, Click on the drop down box located in the top right corner of the listing and select a format from the list (for example, Agent Full or Agent Short). Listings can also be displayed without photographs
- **To print the listing you are viewing**, Click the *Print* button.
- **To print all listings selected**, Click the *To List* button (after selecting any additional listings to be printed), and then select a report from the available reports box at the bottom of the screen. Click the browser's print button to print the reports.

Search By Map

Tempo Mapping – The **Search by Map** option will allow you to select a section of a map to use with other criteria for your search. This map option could be used instead of zip code(s) or Thomas Bros. Map code(s). Use at the beginning of your search before entering any criteria.



Geo-Coding and Mapping Accuracy

The listings are "geo-coded" automatically when they are added. This process encodes the property's latitude and longitude with the listing. However, some properties will not properly "geo-code" because the areas in which they are placed have not been updated by the mapping software. The area may also be too new to have been properly identified. In areas where significant growth has occurred, maps may be improperly drawn and, while they may appear close to their proper location, some listings may be found on the wrong side or the wrong end of a street. MarketLinx will continually adjust the geo-coding software to make sure it is responding as accurately as possible. The Map is a good general representation of the location of a property. It can be an excellent tool when describing a rectangular area in which to locate similar properties for CMAs or in doing appraisals.

 The Map can be accessed from both Quick and Custom Searches.

Performing the Map Search:

Step 1 From Tempo™ Tool Bar, hover over **Search**, Click **Quick Search** and the Quick Search screen will appear.



Step 2 The Quick Search screen contains the property criteria to be searched in the available property types (i.e. Residential, Commercial, Land and Business, etc.)

Step 3 Click **Search by Map** on the Floating Toolbar. The Search by Map screen appears.

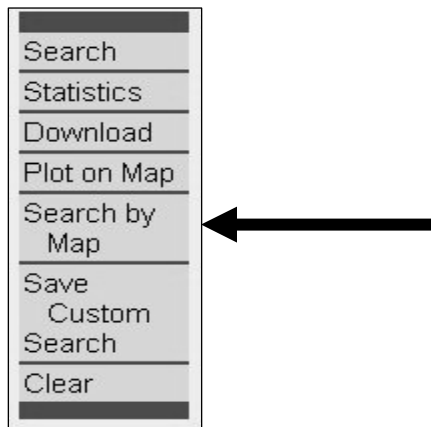

- Step 4** Your search area can be narrowed quickly by using the section on the right. The information entered here will direct Tempo where you want your map to be focused. Upon entering, Click the Submit button to have map centered on that location.

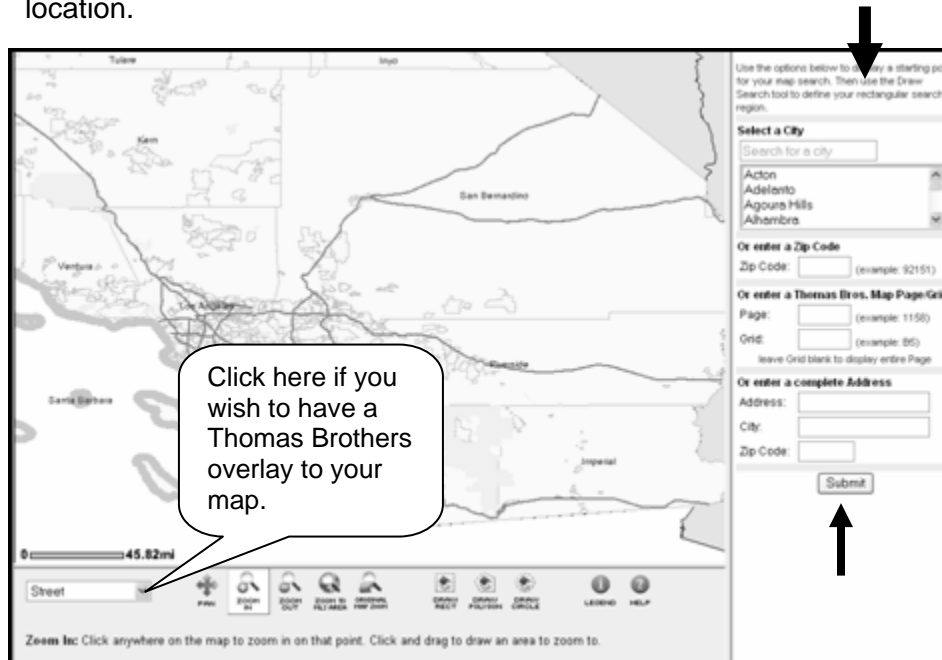

Map Tools

- **Zoom In** – is selected when you enter the map screen. Click anywhere on the map to zoom in to that area. It will zoom closer with each mouse click.
- **Zoom Out** – Click on tool to activate. When activated, you can zoom out each time you click on any area of the map.
- **Pan** – Click on tool to activate. When active you can click and “grab” the main map display and drag it to a new location while you hold your left mouse button down. When you release the mouse button, the main map redraws with a new view.
- **Draw Rect** - Click on tool to activate. When active you can draw a selection rectangle by Clicking on the main map display, holding down your left mouse button while you draw a box. When done, Click the *Apply to Search Criteria* button, you will return to your search screen where you can enter any additional criteria for your search.
- **Draw Polygon** - Click on tool to activate. When active you can draw a selection by Clicking on the main map display, holding down your left mouse button while you draw a shape with up to six sides. When done, Click the *Apply to Search Criteria* button, you will return to your search screen where you can enter any additional criteria for your search.
- **Draw Circle** - Click on tool to activate. When active you can draw a selection circle by Clicking on the main map display then scrolling away from the Click point to create your circle. When done, Click then Click the *Apply to Search Criteria* button, you will return to your search screen where you can enter any additional criteria for your search.

- **Original Map Zoom** – In the **Search By Map** option, it will do the same as **Zoom to MLS Area**.
- **Zoom to MLS Area** – Click to return the map to the entire MLS market area.
- **Legend** – Displays the map legend

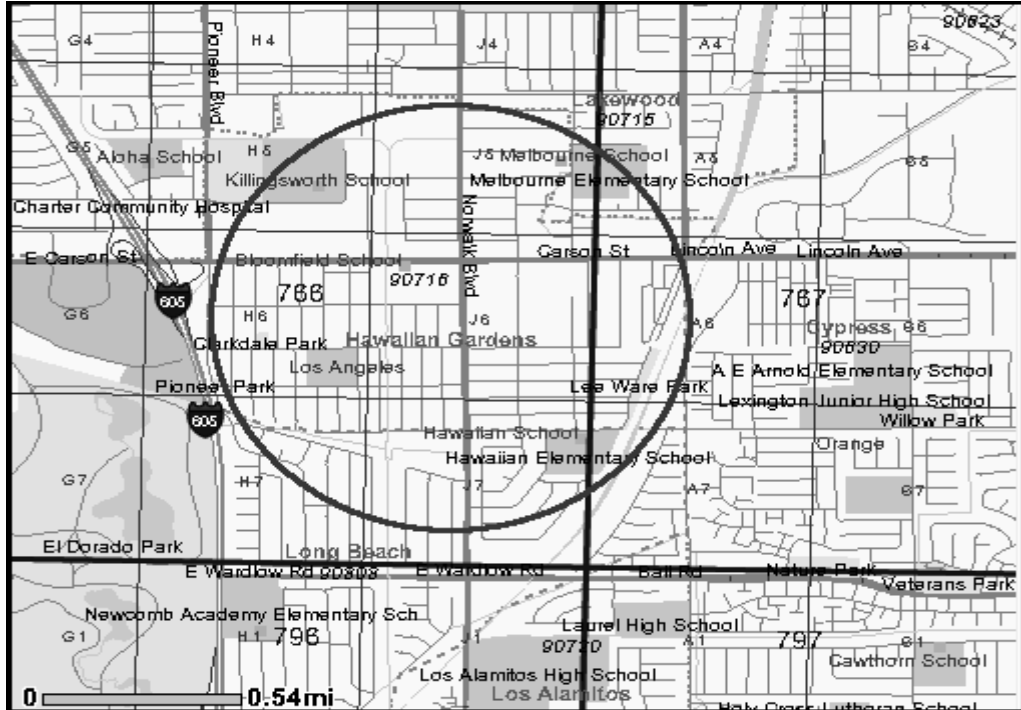

Step 5 Once you have selected your geographical area, Click *Apply to Search Criteria* button, to be returned to the Quick Search Form.

To remove the Map coordinates; simply Click the **Map Clear** Button, which will now appear on the floating toolbar.

Residential	Res Lease	Res Income	Mobile/Modular/Manufactured	Land	Commercial	Com Lease	Business	All
Search	Select		Status		Property Information			
Statistics	Type in codes for the selections separated by commas or click on "Select" below.		Clear	Check All	Price	Min	Max	
Download	Select Clear		Active	Off-Mkt	Beds			
Plot on Map	County		<input type="checkbox"/> -- ALL -- <input type="checkbox"/> Active <input type="checkbox"/> Backup Offers <input type="checkbox"/> Cancelled <input type="checkbox"/> Closed Sale <input type="checkbox"/> Expired <input type="checkbox"/> First Right of Refusal <input type="checkbox"/> Hold Do Not Show <input type="checkbox"/> Leased <input type="checkbox"/> Pending Sale		Baths			
Search by Map	City				Living SqFt			
Map Clear					Year Built			
Save					Garage			
Custom Search					Lot Size			
Clear								

Step 6 Enter any additional criteria for your search.

Step 7 Click **Search** to see search results as in any other search or Click **Map** to see results mapped. The results will only include properties located within the selection box of the map that match your criteria.

Custom Search

Custom Search allows users to create personalized searches for their clients/prospects specific needs. The Custom Search also offers all listing fields as searchable data.



Step 1 From the Tempo™ Tool Bar, hover over **Search**, Click **Custom Search/Reports** and choose a Property type.

Step 2 The Saved Searches section lists all of the custom searches previously created for that property type.

- To Create a new Custom Search Click the **Create Custom Search** Button
- To Access a previously created Custom Search, Click on the **NAME** of Saved Search



- The *Custom Search* screen is made up of several components: the *Saved Searches* box, the *Search for Field*, *Available Fields*, *Selected Fields*, a *Search Name* box, and several buttons.

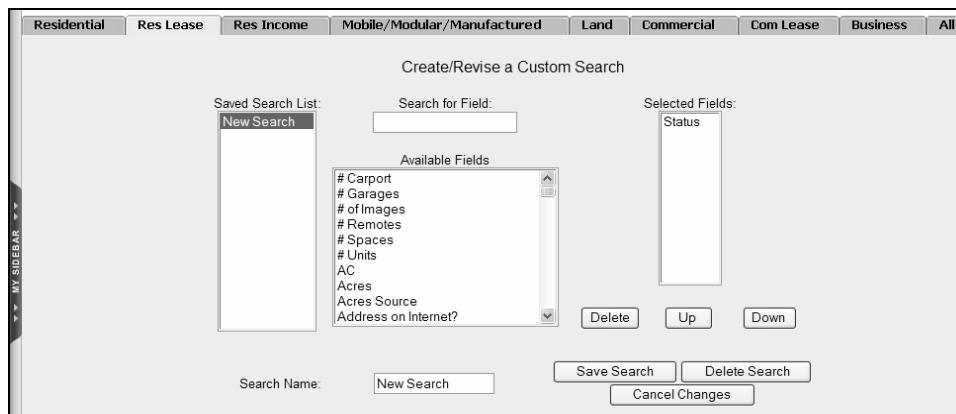



- Select fields from the *Available Fields* box by Clicking on them. This will move them to the *Selected Fields* box where they will be available as search criteria.
- The *Search for Field* allows you to enter the criteria label so you won't need to scroll through all the fields.



- In the *Search Name* box enter a name for the custom search and Click on the **Save Search** button.
- To delete the search, go to the *Create Custom Search* screen. Select the search and Click on the **Delete Search** button.

Execute a Custom Search

After saving a *Custom Search*, a screen appears where the user can enter the search criteria specified for the client.

From here you can:

- Search listings
- Run Statistics
- Save search criteria
- Revise Search
- Search By Map
- Download Listings
- Map Listings
- Attach to Existing Prospect
- Attach to New Prospect



☛ Custom Searches offer all the same functions as Quick Searches, i.e. e-mail, print, etc.

Revising Custom Search

To change a custom search, scroll to the bottom of the *Create Search* screen and Click on the **Revise Search** button. Make any desired changes then scroll to the bottom of the page and Click on the **Save and Search** button. This saves the changes made to the search and brings up the revised *Custom Report*, which lists the properties that match the revised criteria.



It is important to review and perhaps print a copy of the *Search Results* List. Each time the custom search is generated a new search of the entire database is executed.

MLS Tour/Public Open House Search

Directions for Tempo's MLS Tour feature:

Step 1 Hover over Search and MLS Tour/Public Open House



Step 2 The MLS Tour/Public Open House search screen will appear

Use Scroll bars to access more search fields

Search Tips

- Click to view options
- Click to close option window

Current Criteria – displays the criteria of your current search.

Count – displays the number of records that match your search criteria.

Additional Fields – allows you to add additional fields to your search.

Searching Tour Dates

There are two ways of selecting Tour Dates:



a) Quick Pick - Click the **v** to open up a window with search day(s), Click option that applies.

The screenshot shows the 'Search Form' section of the MLS interface. The 'MLS Tour/Public Open House Date' field is set to 'From: 8/15/2007' and 'To:'. A dropdown menu is open, showing options: 'Quick Pick...', 'Today', 'Tomorrow', 'Next 3 Days', 'Next 7 Days', and 'Next 2 Weeks'. The 'Quick Pick...' option is highlighted. The interface also includes a 'Search Criteria' sidebar, a 'Search Map' tab, and a 'Count' field.

b) Calendar Search -

Click the calendar icon to open a window with monthly calendars, then Click the desired date(s)

The screenshot shows the 'MLS Tour/Public Open House Date' field with a calendar icon. Two monthly calendars for August 2007 are displayed side-by-side. The 'From' calendar shows dates from 25 to 31, and the 'To' calendar shows dates from 25 to 31. A 'Quick Pick...' dropdown menu is visible to the right of the calendars.

Step 3 After all search criteria is entered, Click the search icon  Search or  Map Results to begin your search.

Step 4 The Search Results screen will appear

ML Tour / Public Open House Search

Search Criteria Search Results

Revise Search Save Search

Email Print

Search Results: 2 Listings / 0 Selected

Residential Open House + Multi-Field Sort

#	MLS #	Date	Status	P	V	H	T	Q	Use	A/D	Address	City	Area	Zip	TGNO	Tract	BD	BA	Gar	SqFt	YB	List Price
1	<u>S483615</u>	08/22/2007	A	13	V	H	T	Q	SFR	D	<u>31975 Mill Stream Rd</u>	RSM	RR	92679	<u>863D7</u>	THE	4	3.00	3	2507	1987	\$875,000
<p>L/O: Jerry La Mott (dlamoje) 949-472-9191 L/O: Prudential Calif Realty (D318) 949-425-9600 Builder Tract Name: Trabuco - Elms</p> <p>X Street: ROBINSON RANCH / PLANO TRABUCO Stories: Two Levels Pool: Assoc Pool DOM: 129 Gate Code: S/O Comp: 2.50</p> <p>Property Description: Beautiful 4 bedroom, 3 bath home. Downstairs bedroom converted to a den. Pristine condition with wood flooring & soaring ceilings. Light and bright with neutral paint & carpet. Upgraded kitchen has attractive cabinetry with granite counters & stainless appliances. Lush landscape with mature trees. The long driveway is set back from the street giving the home both privacy and seclusion. Close to community pool, park, tennis courts & schools. READY TO MOVE-IN!</p> <p>Date: 8/22/2007 Time: 10:00:00 AM-02:00:00 PM Refreshments: Other Type: MLS Tour Attended: Y</p> <p>Comments: test</p>																						
2	<u>S477244</u>	08/31/2007	A	4	H	T	Q	CONDO	A	A	<u>26152 La Real</u>	MV	MN	92691	<u>892A5</u>	BLP	0	1.00	0	450	1984	\$255,000*

Check All Narrow Selected Restore List Show Criteria

Map

Reports: Agent MLS Tour/Public Open House Report Go

From the Search Screen:

- Click the + symbol to open up a thumb nail view of the listing
- All items underlined are links to more listing information
- Toggle back and forth between Search Criteria Screen and Search Results Screen by Clicking on the folder header
- Click Check All icon to select ALL listings at once
- Click on the Map icon to map selected listing and don't forget that now you can get driving directions from Tempo Maps!
- Click V at Reports to view all the reports offered (for viewing and or printing)
- Click Email icon to email selected listings
- Click Print icon to print selected listings

Tempo Driving Directions

Take advantage of Tempo's easy to use driving directions feature available from all Searches, MLS Tour Reports and Hot Sheets.

From the search results screen:

Step 1 Select listings you wish to map

Step 2 Click the **Map** button

RES	MLS #	Status	P	V	H	T	Q	Type	A/D	Address	City	Area	Zip	TGNO	TrctM	Bd	Bth	Sty	Gar	SqFt	Yr Blt	Price	DOM
1	<input checked="" type="checkbox"/> S453691	A	16		H	I	Q	SFR	D	23131 Pradera Rd.	CDC	CC	92679	893C5	IRE/c	5	9.5	2	4 A	0	1989	\$7,900,000	49
2	<input checked="" type="checkbox"/> S426858	A	20		H	I	Q	SFR	D	31801 Violeta Ln.	CDC	CC	92679	893C5	LRE/Z	6	5.5	2	10 A	9,000	1982	\$10,900,000	231 *
3	<input checked="" type="checkbox"/> S457012	A	14		H	I	Q	SFR	D	31822 Secova Way	CDC	CC	92679	893D3	LRE/C	10	13.5	2	8 A	0	1993	\$19,876,000	24 v
4	<input checked="" type="checkbox"/> S459812	A	10		H	I	Q	SFR	D	31951 Violeta Ln.	cdc	cc	92679	893D4	LRE/Z	7	9.5	2	10 A	15,000	2006	\$22,900,000	3

Results List Functions

Report Functions

Step 3 At the Tempo map screen, **select the listings to be mapped**
(Up to 8 locations may be mapped at one time)

Step 4 Click **Driving Directions**

Step 5 The Driving directions screen will appear -

Driving Directions

Driving directions will be created for a route beginning at the first location listed below and ending at the last location listed. The route will pass by each listed address in the order listed. Use the Up/Down/Remove buttons to re-order the properties as desired. Each additional route location will increase the calculation time for driving directions.

Route Locations

15402 Ashgrove Dr
 15845 Ashgrove Dr
 16003 Ashgrove Dr

↑
MOVE UP
↓
MOVE DOWN
✕
REMOVE LOCATION
📍
SHOW LOCATION

Show Driving Directions

Define Another Location

Use my Office Address

Street Address

Cross Street

City

Zip Code

Add To Route Locations

A - Driving directions will be created for a route beginning at the first location listed under Route Locations. The route will pass by each listed address in the order listed. Use the Up/Down/Remove buttons to re-order the properties as desired.

B - **Define Another Location** - from here you can add additional location to the driving directions; for example, if you are starting from your home you may wish to add your home address, then click the *Add to Route Locations* button. Be sure and move your home address to the top of the list so your directions will be in the correct order.

Step 6 Click the **Show Driving Directions Button** to receive a plotted map along with written directions to each location.

Revise Locations

📍
🗑️
+
📍
🖨️

Driving Directions

Estimated Driving distance: 9.1 mile(s) • Estimated Driving time: 13 minute(s)

- 1 Depart 101 E Lincoln Ave, 92805, Anaheim, CA
- 2 Go North on N Anaheim Blvd - Drive < 0.1 mile(s) - < 1 minute
- 3 Turn left on W Cypress St - Drive < 0.1 mile(s) - < 1 minute
- 4 Turn left on N Anaheim Blvd - Drive < 0.1 mile(s) - < 1 minute
- 5 Turn right on W Lincoln Ave - Drive 1 mile(s) - 2 minute(s)
- 6 Turn left on N Wilshire Ave - Drive < 0.1 mile(s) - < 1 minute
- 7 Take ramp and go North West on I5 (Santa Ana Fwy) - Drive 4.1 mile(s) - 4 minute(s)
- 8 Take ramp to Ramp - Drive 0.3 mile(s) - < 1 minute
- 9 Straight on Ramp - Drive < 0.1 mile(s) - < 1 minute
- 10 Turn left on Manchester Blvd - Drive 0.4 mile(s) - < 1 minute
- 11 Go North on SR 39 (Beach Blvd) - Drive 1.2 mile(s) - 2 minute(s)
- 12 Turn left on La Mirada Blvd (Malvern Ave) - Drive < 0.1 mile(s) - < 1 minute
- 13 Straight on La Mirada Blvd (S Mirada Blvd) - Drive 0.3 mile(s) - < 1 minute
- 14 Straight on La Mirada Blvd - Drive 0.2 mile(s) - < 1 minute

Roster

The Roster search is a great tool when seeking contact information for other members and offices. The Edit My Roster function allows you to update your personal contact information on Tempo™.

Step 1 From the Tempo™ Tool Bar, hover over Member Info, from the drop down menu, hover over Roster **Roster**.



Step 2 Click:
Search for Members – to search SoCalMLS agents
Search for Offices – to search SoCalMLS offices
Edit My Roster – to modify your personal information

- Enter only the information in the fields that is known to be correct. For example, to find a member named Bill Kelly, only enter the last name Kelly and Click **Search**. A list of all the members with the last name Kelly will appear. Click on the **member's link** and the member's contact information is shown.
- The *Member Search* can also be used to find all the members associated with a certain office. Enter the appropriate Office Code and Click **Search**. All the members associated with that office are listed.
- Office Search, Click on the desired field and type in the information known about the office. For example, to find the address of Hometown, U.S.A., type *Home* in the *Office Name* text box and Click the *Search* button.
- Other search options include City or Zip Code, Office Code, Address, or E-Mail address then Click **Search**.

- The Edit My Roster option will bring up your record, there you can update your personal contact information. Click **Update Information** to save changes.

Information	
Public ID (Shown in links to agent data)	XTERRY
Login ID	XTERRY
Display Name	Terry Matt
Designations	
Preferred Phone	714-517-2600
Preferred Phone Ext.	
Preferred Fax	714-517-2604
Mobile Phone	555-555-5555
Voice Mail	555-777-7777
Voice Mail Ext.	
Home Phone	
Pager #	
E-Mail Address	terry@socalmls.com
Website Address	http://
Receive Status Updates via Email	Yes
Receive Product Notices via E-Mail	Yes

Adding Your Agent Photo To Tempo™

Step 1 From the Tempo™ Tool Bar, hover over My Tools, Click **My Page** from drop down menu.

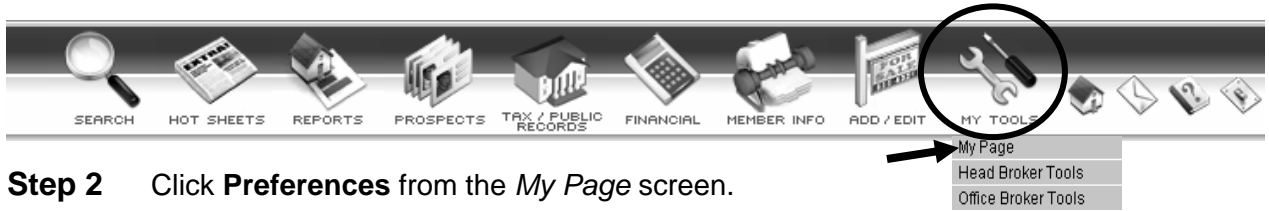

Step 2 Click **Preferences** from the *My Page* screen.

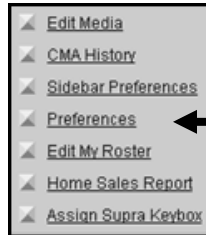

This takes you to the General Preferences screen.

Step 3 Click **Browse**

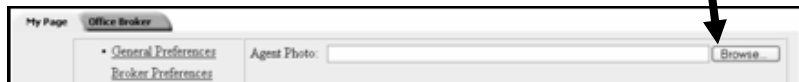

- ✍ This will open up the *Choose file* window. Browse files on your computer, locate your photo file
- ✍ Click the **photo file**
- ✍ Click **Open**



Your photo path now appears in the *Agent Photo:* box
Click **Save**

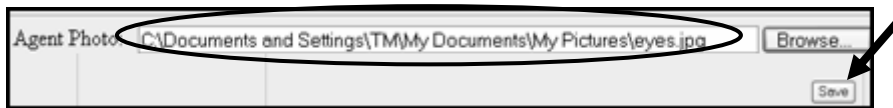

Once photo is saved, the **View Image** link appears – Click to View Image

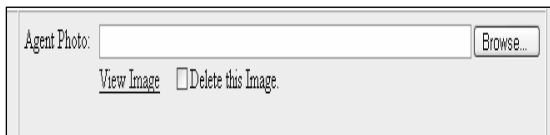

The *Agent photo* Window will display your photo!

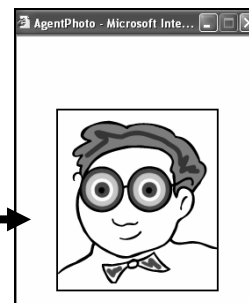

✍ Agent Photos can be changed as often as you wish.

Adding E-Mail Signature

Step 1 From the Tempo™ Tool Bar, hover over My Tools, Click **My Page** from drop down menu.

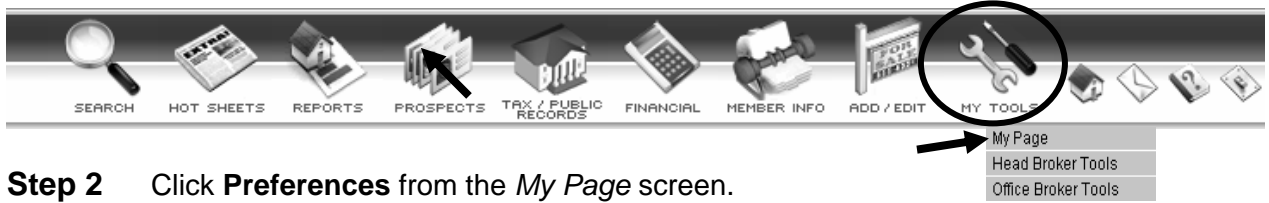

Step 2 Click **Preferences** from the *My Page* screen.



Step 3 Click **Email Preferences**



- ✂ The Signature Box will now be shown on your screen.
- ✂ Enter your desired E-mail Signature.
- ✂ Click **Yes** to make this your default e-mail.
- ✂ Click **Save**.

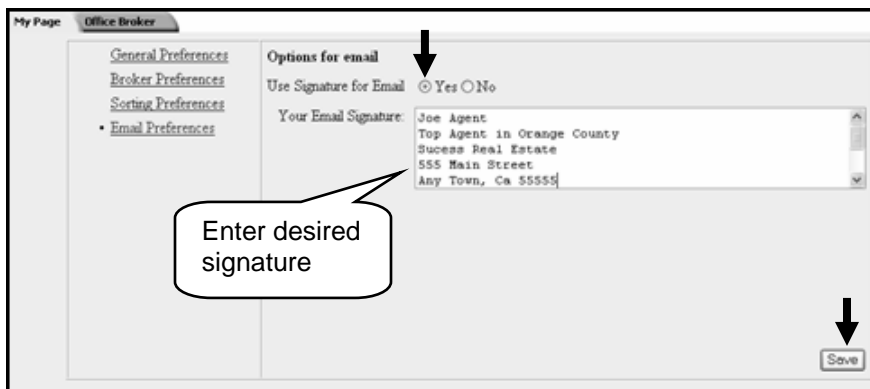

☞ This will become your default E-mail signature but can easily be changed or updated at any time from e-mail screen for individual e-mail, or by following the steps above.